

RADIALL DETAIL SPECIFICATION FOR SEMI-RIGID COAXIAL CABLE

Rédigé par / Written by	Responsabilité / Responsibility	Date	Signature
S. POIZAT	Space Project Manager	19/08/2015	
V. EUDELIN	Space B. U. Manager	19/08/2015	
C. DAVENEL	Space Quality Manager	19/08/2015	

	DETAIL SPECIFICATION	
	REF. : RAD-DET-CABL-001	
	Date: August 19 th , 2015	ED/REV: 1 C

DOCUMENTATION CHANGE NOTICE

REVISION OR ISSUE	DATE	CHANGE
1	28/05/03	Creation- Replacement of specification R294-CABL Issue 1
1A	03/05/04	Characteristics of low loss cable updated. Reference to M17/133-00002 for .085 cable deleted.
1B	06/08/10	Updated with corrections of the technical performances of the cable + add the Microcoax references.
1C	19/08/2015	Updated to change the bending radius for SR .085"LL and .141"LL



	DETAIL SPECIFICATION	
	REF. : RAD-DET-CABL-001	
	Date: August 19 th , 2015	ED/REV: 1 C

TABLE OF CONTENTS

1. SCOPE	4
2. CABLE CHARACTERISTICS	5
2.1. Semi-rigid cable .085 (Radiall P/N: C291 851 601 – UT85 C M17)	5
2.1.1. Dimensions and Materials	5
2.1.2. Electrical Characteristics	5
2.1.3. Mechanical and Environmental Characteristics	5
2.2. Semi-rigid .085 micro-porous (Radiall P/N: C291 852 661 – UT85 C LL)	6
2.2.1. Dimensions and Materials	6
2.2.2. Electrical Characteristics	6
2.2.3. Mechanical and Environmental Characteristics	6
2.3. Semi-rigid cable .141 (Radiall P/N: C291 861 661 – UT141 HA M17)	7
2.3.1. Dimensions and Materials	7
2.3.2. Electrical Characteristics	7
2.3.3. Mechanical and Environmental Characteristics	7
2.4. Semi-rigid .141 micro-porous (Radiall P/N: C291 859 661 – UT141C LL)	8
2.4.1. Dimensions and Materials	8
2.4.2. Electrical Characteristics	Erreur ! Signet non défini.
2.4.3. Mechanical and Environmental Characteristics	8

	DETAIL SPECIFICATION	
	REF. : RAD-DET-CABL-001	
	Date: August 19 th , 2015	ED/REV: 1 C

1. SCOPE

This specification is a detail specification for cables used in semi-rigid cable assemblies. It shall be read in conjunction with RADIALL generic specification RAD-GEN-CSRS-001 concerning semi-rigid cable assemblies.

This technical specification describes all the electrical and mechanical parameters of coaxial cables used for the manufacturing of semi-rigid coaxial cable assemblies for SPACE market.

These cables are specific and cannot be sold separately, they are considered as part of coaxial cable assemblies. They are qualified according to MIL C 17 G and supplied by qualified manufacturers. Purchasing conditions and incoming inspection tests are described in the Radiall document RAD-APP-CABL-001.

	DETAIL SPECIFICATION	
	REF. : RAD-DET-CABL-001	
Date: August 19 th , 2015	ED/REV: 1 C	PAGE : 5/ 8

2. CABLE CHARACTERISTICS

2.1. Semi-rigid cable .085 (Radiall P/N: C291 851 601 – UT85 C M17)

2.1.1. Dimensions and Materials

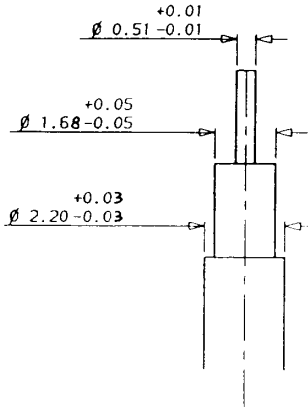

Parts	Material	Plating
Outer Conductor	Copper	-
Dielectric	PTFE	-
Centre Conductor	Copper	Silver 2 μ mini

2.1.2. Electrical Characteristics

Characteristics	Values	Units
Characteristic Impedance	50 \pm 1,5	Ohm
Capacitance	105	pF/m
Dielectric Withstanding Voltage	5000	VRMS at 60Hz
Corona Extinction Voltage	1500	VRMS at 60Hz
Frequency Range	DC – 20	GHz
Maximum Insertion Loss		dB/m
0,5 GHz	0,49	
1 GHz	0,72	
5 GHz	1,64	
10 GHz	2,62	
20 GHz	4.27	
Maximum Structural VSWR		-
500 MHz	1,08	
5 GHz	1,15	
20 GHz	1,43	
Power Handling at 20°C, sea level		Watts
0,5 GHz	180	
1 GHz	130	
5 GHz	54	
10 GHz	35	
20 GHz	20	

2.1.3. Mechanical and Environmental Characteristics

Characteristics	Values	Units
Maximum Mass	22.6	g/m
Minimum Inside Bend Radius	1.27*	mm
Operating Temperature Range	-40 ; +125	°C
Storage Temperature Range	-40 ; +125	°C

* For Radiall production, the nominal Bend Radius used is 7mm

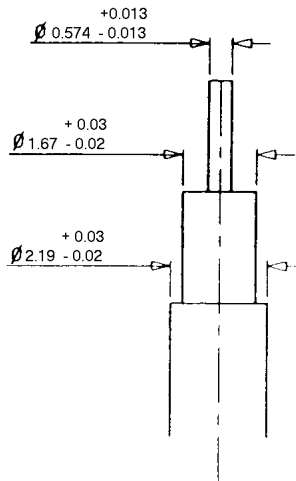
2.2. Semi-rigid .085 micro-porous (Radiall P/N: C291 852 661 – UT85 C LL)
2.2.1. Dimensions and Materials

Parts	Material	Plating
Outer Conductor	Copper	-
Dielectric	Micro-porous PTFE	-
Centre Conductor	Copper	Silver 2µ mini

2.2.2. Electrical Characteristics

Characteristics	Values	Units
Characteristic Impedance	50 ± 1,5	Ohm
Capacitance	87,3	pF/m
Dielectric Withstanding Voltage	2500	VRMS at 60Hz
Corona Extinction Voltage	1500	VRMS at 60Hz
Frequency Range	DC – 64	GHz
Maximum Insertion Loss		dB/m
0,5 GHz	0,41	
1 GHz	0,58	
5 GHz	1,32	
10 GHz	1,88	
20 GHz	2,71	
Power Handling at 25°C, sea level		Watts
0,5 GHz	340	
1 GHz	239	
5 GHz	105	
10 GHz	73	
20 GHz	50	

2.2.3. Mechanical and Environmental Characteristics

Characteristics		Units
Maximum Mass	20.7	g/m
Minimum Inside Bend Radius	6,35*	mm
Operating Temperature Range	-40 ;+250	°C
Storage Temperature Range	-40 ;+250	°C

* For Radiall production, the nominal Bend Radius used is 8mm

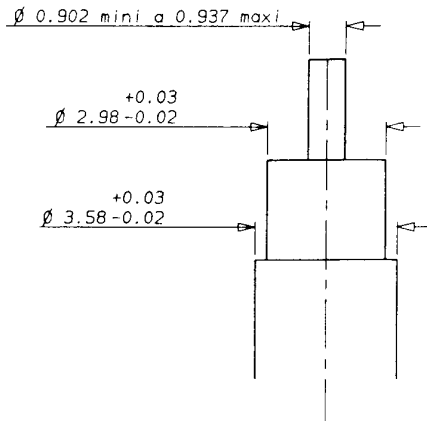
2.3. Semi-rigid cable .141 (Radiall P/N: C291 861 661 – UT141 HA M17)
2.3.1. Dimensions and Materials

Parts	Material	Plating
Outer Conductor	Copper	-
Dielectric	PTFE	-
Centre Conductor	Copper	Silver 2 μ mini

2.3.2. Electrical Characteristics

Characteristics	Values	Units
Characteristic Impedance	50 \pm 1,0	Ohm
Capacitance	98,1	pF/m
Dielectric Withstanding Voltage	5000	VRMS at 60Hz
Corona Extinction Voltage	1900	VRMS at 60Hz
Frequency Range	DC – 20	GHz
Maximum Insertion Loss		dB/m
500 MHz	0,26	
1 GHz	0,39	
5 GHz	0,95	
10 GHz	1,48	
20 GHz	2,30	
Maximum Structural VSWR		-
500 MHz	1,07	
5 GHz	1,15	
18 GHz	1,21	
Power Handling at 25°C, sea level		Watts
500 MHz	600	
1 GHz	450	
5 GHz	180	
10 GHz	120	
20 GHz	70	

2.3.3. Mechanical and Environmental Characteristics

Characteristics		Units
Maximum Mass	51.2	g/m
Minimum Inside Bend Radius	6.35*	mm
Operating Temperature Range	-40 ; +125	°C
Storage Temperature Range	-40 ; +125	°C

* For Radiall production, the nominal Bend Radius used is 11.8mm

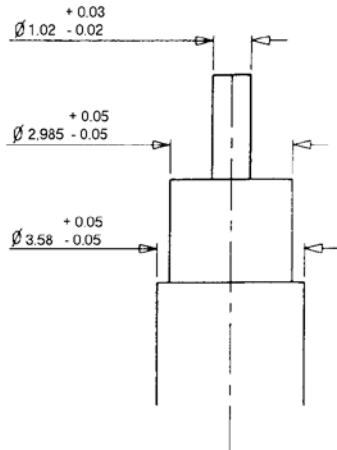
2.4. Semi-rigid .141 micro-porous (Radiall P/N: C291 859 661 – UT141C LL)
2.4.1. Dimensions and Materials

Parts	Material	Plating
Outer Conductor	Copper	-
Dielectric	Micro-porous PTFE	-
Centre Conductor	Copper	Silver 2µ mini

Characteristics	Values	Units
Characteristic Impedance	50 ± 1,5	Ohm
Capacitance	87,3	pF/m
Dielectric Withstanding Voltage	5000	VRMS at 60Hz
Corona Extinction Voltage	1900	VRMS at 60Hz
Frequency Range	DC – 36 GHz	GHz
Maximum Insertion Loss		dB/m
0,5 GHz	0,23	
1 GHz	0,33	
5 GHz	0,75	
10 GHz	1,09	
20 GHz	1,59	
Power Handling at 25°C, sea level		Watts
0,5 GHz	821	
1 GHz	576	
5 GHz	249	
10 GHz	172	
20 GHz	117	

2.4.2. Mechanical and Environmental Characteristics

Characteristics	Values	Units
Maximum Mass	47.6	g/m
Minimum Inside Bend Radius	12,7*	mm
Operating Temperature Range	-40 ;+250	°C
Storage Temperature Range	-40 ;+250	°C

* For Radiall production, the nominal Bend Radius used is 14.5mm