

Contents

Introduction

R2CT®: Radiall 2 Connectors to Transceiver	6-2
Applications	6-2
International Standard Documents Compliance	6-2
Features and Benefits	6-2

Characteristics

Mechanical Characteristics	6-3
Environmental Characteristics	6-3

Product Range

R2CT® Standard Plug Kit	6-4
R2CT® Short Plug Kit	6-5
R2CT® Standard Receptacle	6-6
R2CT® Receptacle With LC Adapter	6-7
R2CT® Field Adapter Plug-Plug	6-8

Tools and Accessories

R2CT® Adapter N-RJ45	6-9
R2CT® Extension Kit	6-9

Cable Assemblies

R2CT® Pre-mounted Optical Cable Assemblies	6-10
R2CT® Pre-mounted On RJ45 Cable Assemblies	6-10
Patchcords	6-11

Introduction

R2CT®: RADIAL 2 CONNECTORS TO TRANSCEIVER



The Most Flexible Outdoor Interconnection Solution

The R2CT® connection system is the most flexible outdoor interconnection solution that meets the needs of telecommunication OEMs and operators for Fiber-To-The-Antenna (FTTA) and similar multisignal applications in the field conditions.

At the panel front of the Remote Radio Head (RRH) and Unit (RRU) equipment, the R2CT® provides a simple and protected low-cost waterproof and sealed connection.

Designed firstly for optical links using SFP transceivers and duplex LC-terminated fiber-optic cable, this very flexible connector is also useful for electrical links.

APPLICATIONS

FTTA: Fiber To The Antenna

Outdoor Telecom

Industrial Connection



INTERNATIONAL STANDARD DOCUMENTS COMPLIANCE

- IEC 61300: Fiber optic interconnecting devices and passive components
- IEC 60068: Environmental testing
- IEC 60529: Degrees of protection provided by enclosures (IP code)
- RoHS compliant



FEATURES AND BENEFITS

Flexible and Modular

- Kit assembles in the field over existing optical patchcords
- Compatible with any standard optical LC field cable assembly
- Compatible with any standard SFP transceiver
- Reusable allowing cables and transceivers to be easily changed in the field, including front-panel swapping of transceivers
- R2CT® connection system can easily be used for other Ethernet and multisignal applications: compatible with RJ45 patchcords and USB connections

Robust and Easy to Install

- Double bayonet locking system ensures mechanical connection, allowing a tool less hand-tightened connection
- Kit assembled in the field without tools
- Designed to withstand climatic working conditions of outdoor field applications
- Plug assembly includes a protection cap that can be used for pulling cable

Mechanical and Environmental Protection

- Waterproof
- Dustproof
- Important tensile strength

Low Cost

Characteristics

R2CT® connector has been designed to fulfill the qualification requirements of IEC 61300 standard (for fiber optic interconnection devices)

MECHANICAL CHARACTERISTICS

Cable retention	200 N
Mating endurance	100 mating cycles minimum

ENVIRONMENTAL CHARACTERISTICS

Ingress protection class	IP65 or IP67
Operating temperature	-40°C/+85°C
Storage temperature	-40°C/+85°C
Salt mist	IEC 61300-2-26 passed
Vibrations	IEC 61300-2-1 passed

Product Range

R2CT® solution is available as a component (Plug Kit) to fit in the field on any conventional LC or SC optical connector or as a complete cable assembly.

A short version of the R2CT® Plug Kit has also been developed with reduced overall dimensions, which is especially well adapted to electrical links such as RJ45 connections or optical multichannel (MPO).

R2CT® STANDARD PLUG KIT

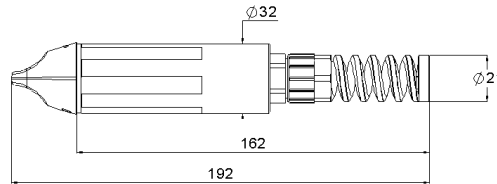

Part Number	Description	Packaging
R2CT 115 000	Plug connector only; no patchcord	Unitary in plastic bag with assembly note

The R2CT® Plug Kit is adapted to all types of optical cable assemblies with simplex or duplex LC connectors, simplex SC, and with 5 to 7 mm diameter MultiMode or SingleMode field cables.

To guarantee proper operation when the R2CT® Plug Kit is assembled over existing LC Duplex optical patchcords, the following fan-out dimensions should be observed:

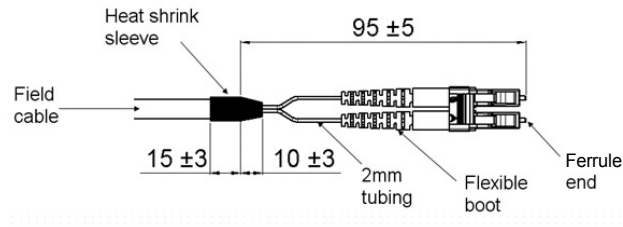

We recommend using a torque wrench (Radiall PN: R282 303 230) set at 3.5 to 4 Nm to guarantee 200 N tensile strength.

The standard R2CT® Plug Kit can also be used with existing SC simplex patchcords:



Product Range

R2CT® SHORT PLUG KIT

The R2CT® Short Plug Kit can fit with any type of electrical Ethernet RJ45 cables with diameters from 5 to 7 mm or optical multichannel MPO cable assemblies.

R2CT® Short Plug Kit connector exists in IP67 version or in IP65 version with split gasket for full assembly in the field.

It is delivered with a pulling nose which protects the connector interface and can include a disconnection clip to disconnect the RJ45 connector from its socket.

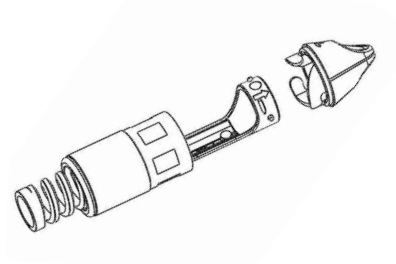
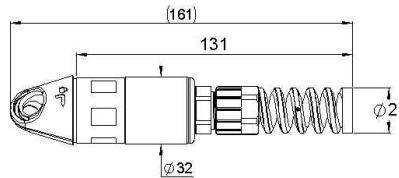

Figure 1

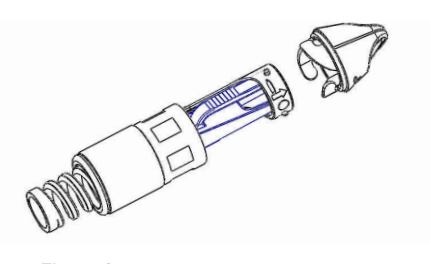

Figure 2

Part Number	Figure	Description	Packaging
R2CT 125 000	1	Kit IP65 Protection (no clip) Plug connector only; no patchcord	Unitary in plastic bag with assembly note
R2CT 125 001	2	Kit IP65 Protection With Disconnection Clip Plug connector only; no patchcord	
R2CT 127 000	1	Kit IP67 Protection (no clip) Plug connector only; no patchcord	
R2CT 127 001	2	Kit IP67 Protection With Disconnection Clip Plug connector only; no patchcord	

The R2CT® Short Plug Kit can be used easily for RJ45 or MPO connection links:



R2CT 127 001 mounted on RJ45 patchcord



R2CT 125 000 with MPO connection

Product Range

R2CT® STANDARD RECEPTACLE

Fixed to the panel of the equipment by four screws, the R2CT® standard receptacle allows an easy access to connect the signal to SFP transceivers for optical links or to RJ45 sockets for Ethernet links.

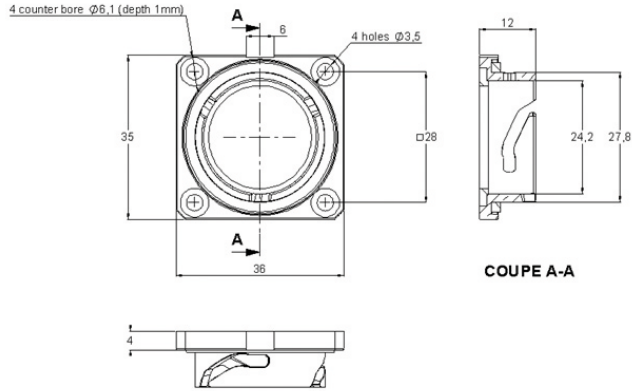

The R2CT® receptacle is supplied with the protection cap installed.

Two possible configurations: red vinyl cap (protection IP65) or aluminium protection cap (IP67).

	Part Number	Description	Panel Cut Out
	R2CT 105 000	Receptacle with red vinyl protection cap	
	R2CT 107 000	Receptacle with metal protection cap	<p>Clearance Holes for M3 Screws</p> <p>$\varnothing 22 \pm 0,1$</p> <p>$\square 28 \pm 0,1$</p>
	R2CT 107 018	Receptacle with metal protection cap with chain	

Product Range

R2CT® RECEPTACLE WITH LC ADAPTER

A variation of the R2CT® receptacle has been developed to include a LC adapter to allow the R2CT® interface to be used with equipment in which the SFP transceiver is inside the box (RRU of first generation, etc).

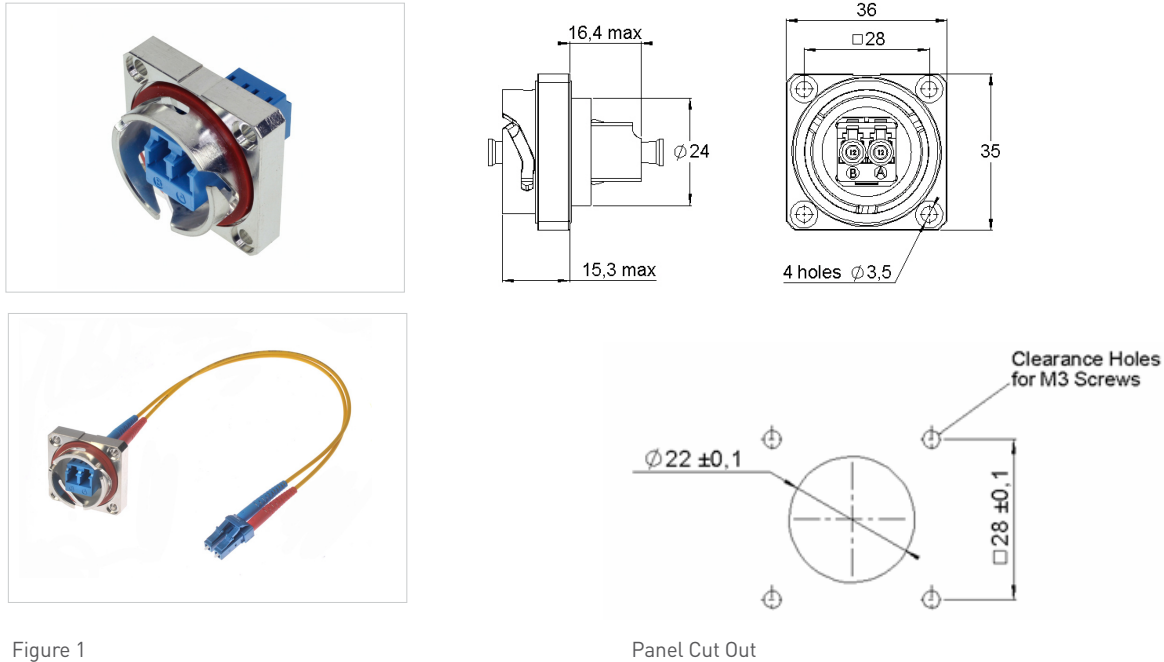

Figure 1

Panel Cut Out

Part Number	Figure	Description	Packaging
R2CT 107 100	1	R2CT® receptacle with LC duplex adapter and LC duplex patchcord, SingleMode – IP67	Per 50 pces
R2CT 107 200	2	R2CT® receptacle with LC duplex adapter, no patchcord SingleMode – IP67	Per 56 pces
R2CT 107 300	3	R2CT® receptacle with LC duplex adapter, no patchcord MultiMode – IP67	Per 56 pces



Figure 2

Figure 3

Product Range

R2CT[®] FIELD ADAPTER PLUG-PLUG

This product allows the connection of two R2CT[®] Plug cable assemblies in the field. It includes a standard LC duplex adapter in MultiMode or SingleMode versions.

Two metal Aluminium protection caps protect each side of the R2CT[®] field adapter and provide a robust solution in outdoor conditions.



Part Number	Description	Packaging
R2CT 157 000	Field Adapter R2CT [®] Plug-Plug, with LC duplex adapter, metal cap MultiMode – IP67	Per 30 pces
R2CT 157 001	Field Adapter R2CT [®] Plug-Plug, with LC duplex adapter, metal cap SingleMode – IP67	Per 30 pces

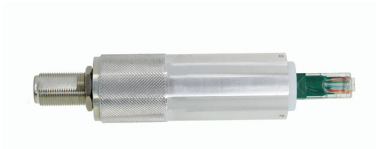
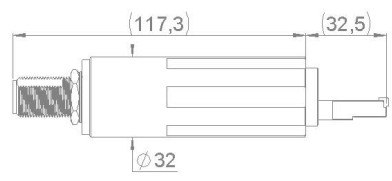

Illustration of use: R2CT[®] Plug Kit
fiber optic cable connected to field adapter

Tools and Accessories

R2CT® ADAPTER N-RJ45

For needs of measurement and control of the RRU and RRH equipment in FTTA applications, a specific version of R2CT® has been developed to adapt the RJ45 connection signal to a coaxial signal with standard N interface.

Picture	Figure	Part Number
		R2CT 135 000

R2CT® EXTENSION KIT

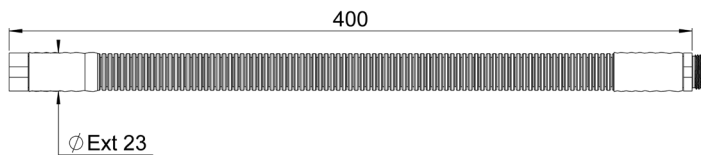

This component allows the use of the standard R2CT® Plug Kit with existing optical patchcords where the fan-out is longer than the one that is recommended to guarantee the solution work properly (95 mm ± 5).

The R2CT® Extension Kit can fit with outdoor cable assemblies including 5 to 7 mm diameter field cables, with a fan-out dimension of up to 450 mm long.

It is mountable in the field and has to be inserted between the R2CT® Plug Kit body and the nut cable gland to guarantee a sealed and robust complete link.

Part Number	Description	Packaging
R2CT 945 000	Extension Kit (plastic) IP67 Temperature range from -40°C to +85°C	Unitary

Cable Assemblies

R2CT® PRE-MOUNTED OPTICAL CABLE ASSEMBLIES

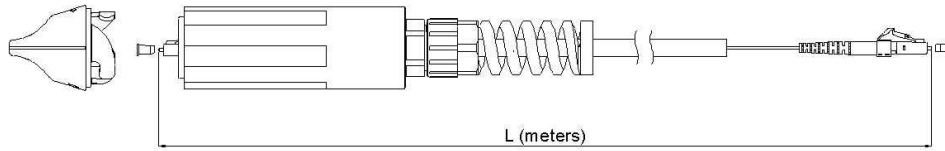

Any configuration for a cable assembly with R2CT® is available on demand:

- Field cables with diameters of 5 to 7 mm on standard
- Standard LC connectors (R2CT® side)
- Any possibility of optical connectors on the opposite side (LC, SC, FC, ST, etc.)
- Simplex or duplex connectors
- MultiMode (50/125 or 62.5/125 on request) or SingleMode (9/125) cable
- Polishing/finishing: PC or APC

OPTICAL CHARACTERISTICS

Insertion Loss (mated with reference plug) (@1310 & 1550 nm)	0.5 dB max
Return Loss (@1310 & 1550 nm)	RL>45 dB

Please refer to Section 9, Cable Assemblies & Optical Systems, for more information.

R2CT® PRE-MOUNTED ON RJ45 CABLE ASSEMBLIES



Pre-assembled R2CT® plug with RJ45 on outdoor patchcord.

R2CT® cable assemblies with RJ45 connectors on 5 to 7 mm diameter cables are available in any length on demand.

Cable Assemblies

PATCHCORDS



LC patchcords



RJ45 patchcord

Radiall can also provide any configuration of LC optical patchcords or RJ45 patchcords for use with the R2CT® Plug Kit. Please refer to Section 9, Cable Assemblies & Optical Systems, for more information.

Notes
