

PAGE 1/1	ISSUE 19 th feb, 2019	SERIES Q-MTITAN™	PART NUMBER F780 735 GA6MR1100
----------	----------------------------------	------------------	---------------------------------------

GUIDE FOR MALE Q-MTITAN VISUAL INSPECTION INSIDE ARINC600

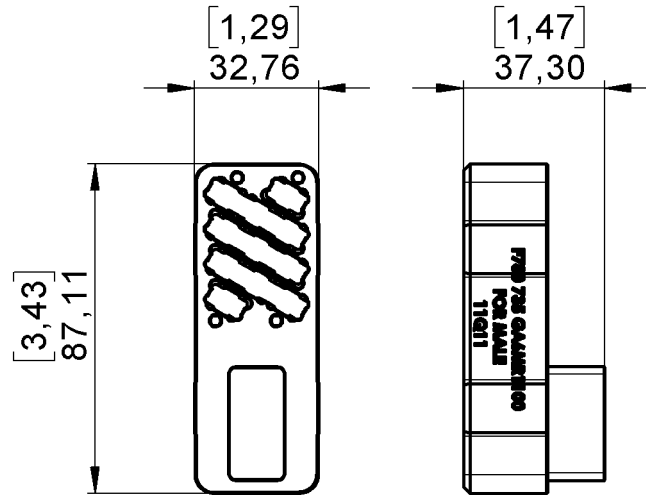

Dimensions in mm [inch]

Q-MTitan™ protects an MT ferrule to maintain excellent optical performance and provide high-density connectivity to harsh environments. Radiall has developed a full range of efficient and convenient tools for the visual inspection of the optical end-faces of the Q-MTitan™.

FEATURES:

- Dedicated guide for male Q-MTitan™ visual inspection inside ARINC600 equipped with 11Q11 insert
- Suitable for F780 735 014 microscope tip and cleaner F780 735 070
- Refer to Radiall Inspection and cleaning procedure for Q-MTitan™: 503 08 840 for further information

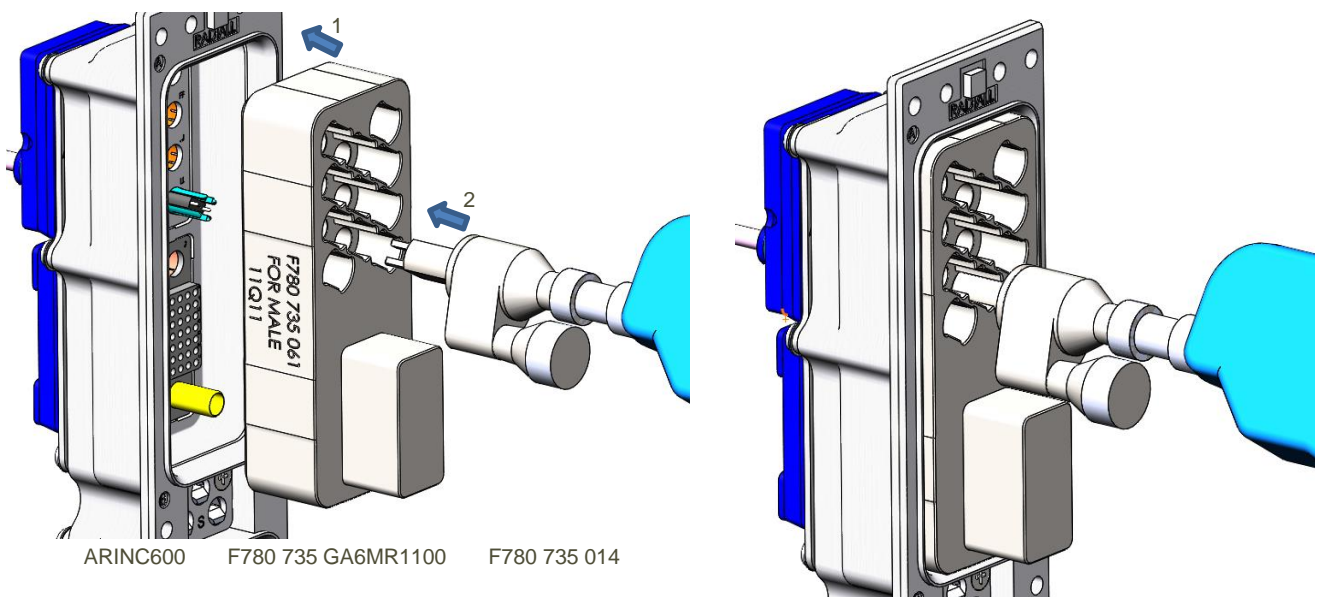

ARINC600 F780 735 GA6MR1100 F780 735 014