

Series
670

SIZE 8 CRIMP COAX SOCKET CONTACT
FOR EN4604-010 (KX) CABLE
ECS 812

Issue:
June 10, 2011

Page
1/1

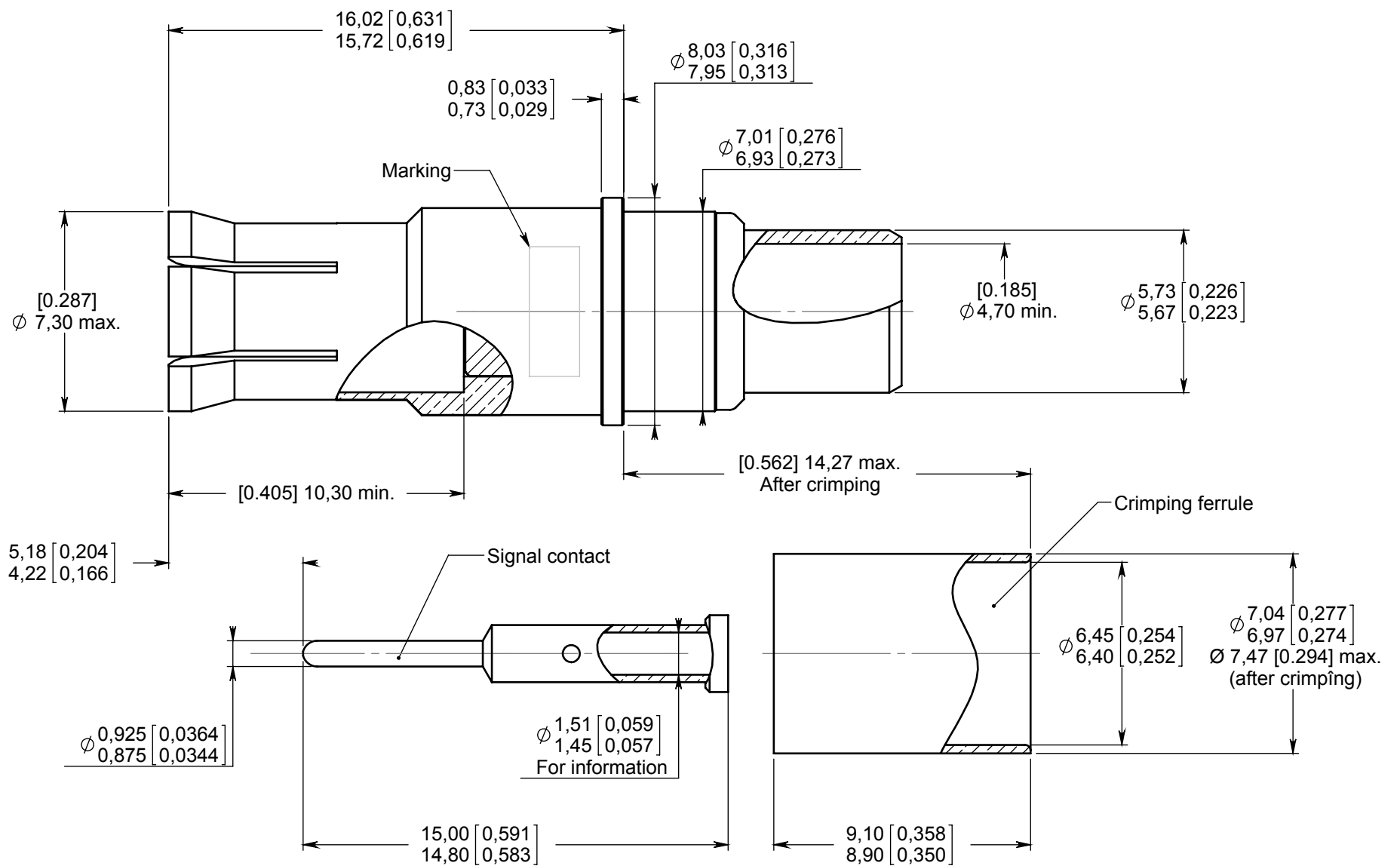

MATERIAL:

OUTER CONTACT : BERYLLIUM COPPER PER ASTM-B - 196
CENTER CONTACT AND CRIMPING FERRULE : BRASS PER QQ-B-626
DIELECTRIC : PTFE PER ASTM-D-1710 OR EQUIVALENT

FINISH :

ALL METAL PARTS : GOLD PER MIL-G-45204 TYPE I or II , GRADE C OR D , CLASS 1 OVER NICKEL PER QQ-N-290

MARKING:

RADIALL --- (Date code) 670 001 007

WEIGHT:

3,7 gr. [0.130 ounces] max.

TOOLING :

CENTER CONTACT : CRIMPING TOOL : M22520/1-01 (RADIALL 282 291)
POSITIONER : RADIALL 282 581 016

OUTER BODY : CRIMPING TOOL : M22520/5-01 (RADIALL 282 293)
DIE : M22520/5-07 HEX A 6.47 [.255] ON FLATS or
M22520/5-13 HEX A 6.47 [.255] ON FLATS or
M22520/5-19 HEX A 6.47 [.255] ON FLATS or
M22520/5-59 HEX A 6.47 [.255] ON FLATS

WIRING INSTRUCTIONS: MI CT 01 00026

DIMENSIONS : mm (inch are given for information only)

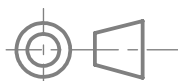

CREATION PEN: 2008-10-2031 OP1007981 NOM: Perrin H. DATE: Nov. 13 2008 APPR.: Garcia L.	June 10, 2011	Note "Non qualified product" cancelled - Weight added Customer specification number added on title.	Perrin H.	Garcia L.
	Dec. 10, 2010	ϕ 5.70 \pm 0,03 was 5,95 - ϕ 4,70 min was 4,75 Add tolerance on ϕ 1,48 (center contact).	Perrin H.	Garcia L.
	March 11, 10	Diam. 4,35 min delated - Center contact crimping tool was M22520/2-01 - Other die P/Ns added for outer body crimping tool.	Perrin H.	Garcia L.
	Feb. 26 10	Center contact positionner P/N and wiring instruction added.	Perrin H.	Garcia L.
	Feb 02 09	Addind dia. 7.47 max. after crimping	Perrin H.	Garcia L.
	Issue	Revisions	Name	Approved

Confidential information not to be disclosed to third parties without Radiall approval. This information is given as an indication. In the continual goal to improve our products, we reserve the right to make any modifications judged necessary.

4112_9311