

Crimp 08 : MCX right angle

COMPONENTS

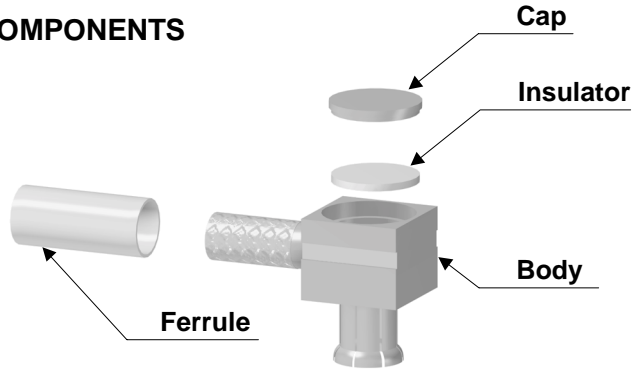

STRIPPING DIMENSIONS

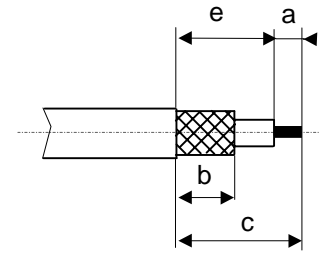

1

Slide the ferrule onto the cable.
Strip the cable.
Tin the cable inner conductor.

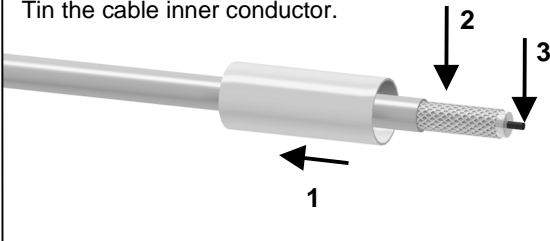

4

Crimp the ferrule with crimping tool (see connector TDS).
Solder the inner conductor.

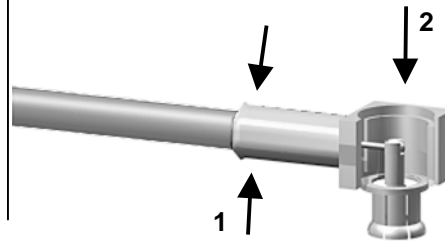

2

Fan the braid.



5

Place the insulator into the body.
Place the cap into the body.

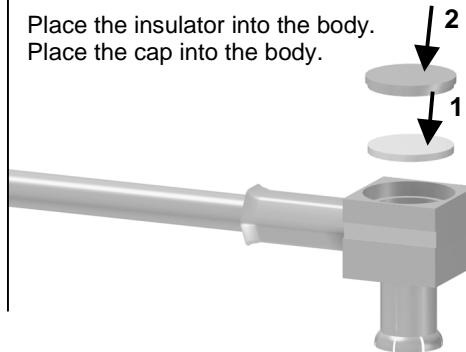

3

Push the connector body under the braid.
Slide the ferrule over the braid.

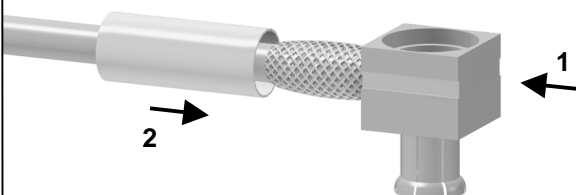

6

Slide mounting tool R282.868.000 onto the body grooves.
Press fit the cap turning tool handle with the adapted wrench of 7mm AF (cap in the same plane than the body square face).

