

Three methods are frequently used in PCB applications to ensure electrical connection and mechanical attachment.

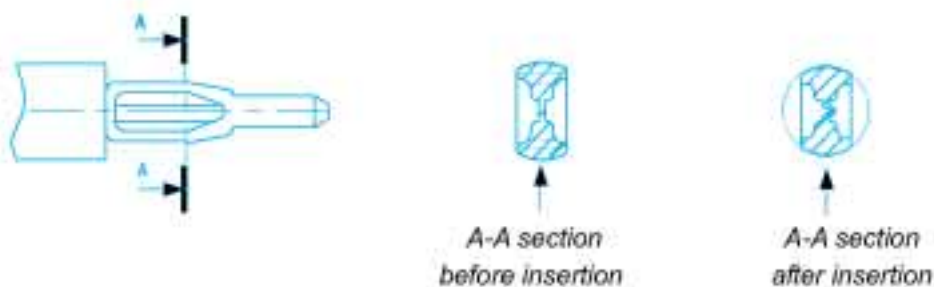

1. Traditional through hole mounting technology: the connector is soldered to the PCB thanks to solder pins penetrating through the PCB.
2. Surface-mount technology: the connector is soldered onto the surface of the PCB,
3. **Press-fit technology** is the only **solderless** method: compliant pins are pressed into the metallized PCB holes. The retention of the component on the PCB is obtained from the deformation of the pins into the holes.



Mechanical retention as well as electrical contact are performed by the compliant pins.

● Coaxipress Product line

Coaxipress designs are available for the following connector series: MCX, SMB, SMA, SMZ BT43, DIN 1.0/2.3, DIN 1.6/5.6, BNC, BR2, TQ (straight and right angle PCB receptacles).
See part numbers list page 15.

Radiall offers full customer support with:

- ➔ technical staff support,
- ➔ detailed instructions for insertion and removal from the PCB
- ➔ tooling.



If you don't find the right connector to fit your needs in these page, please, feel free to contact us for any custom development.



Compared to soldering attachments, COAXIPRESS connectors offer **many advantages**, while offering **comparable electrical and mechanical characteristics**:

C onvenient

- Easy to assemble
- Easy to use tooling
- Fast visual control of the connection. The quality of a soldering joint is far more difficult to check (short-circuit testing, visual control using microscopes or video images...).

F ully repairable

- Connectors can be removed and replaced up to 3 times.
- No need for soldering iron: no temperature stress on other components

C ost efficient



- Time-saving & Money-saving:
 - Press-fit technology, well known for many components such as multipin connectors, can now include coaxial connectors in the same operation.
 - If other components are surface mounted: it is faster to insert a press-fit connector than to solder a connector by hand.
 - No need for expensive equipment (unlike with wave soldering or surface mount techniques)
 - No by-products (such as solder flux or cleaning products).
 - No PCB cleaning step necessary.

Reliable

- ➔ More secure contact :
 - repeatable PCB assembly thanks to specially designed tools
 - no training of workforce, unlike with soldering processes.
- ➔ No risk of connection failure (*see solder joints/press fit technology comparison*).
- ➔ No temperature stress on solder joints, PCB and other components
- ➔ Advantageous for boards with components on both sides: wave soldering or reflow soldering would damage components already mounted on one side of the PCB.
- ➔ Best solution for **large receptacles** (for example for DIN 1.6/5.6 or BNC series) because of the following drawbacks of surface mount techniques:
 - More difficult retention of large connectors on the PCB,
 - A larger connector needs a specific temperature profile to be correctly soldered,
 - Soldering of other smaller components on the circuit may be hindered due to the connector's shadow.

Environmentally friendly

- ➔ No solder fluxes
- ➔ No cleaning products



MAIN ADVANTAGES OF PRESS-FIT TECHNOLOGY



- ◆ Convenient
- ◆ Replaceable connectors
- ◆ Cost efficient
- ◆ Reliable
- ◆ Environmentally friendly

SOLDER JOINTS / PRESS FIT TECHNOLOGY COMPARISON

Solder joints : *many possible failures*

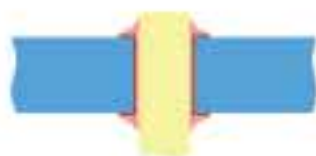

Correctly soldered joint

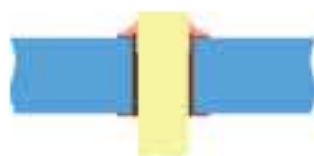

Insufficient solder causing incomplete high resistance joint, and bad mechanical retention

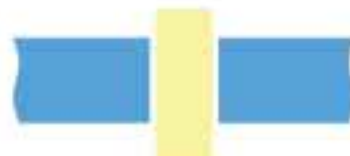

Operator error: joint not soldered



Dewetting case (wave soldering)



Dry joint causing incomplete high resistance joint, and bad mechanical retention



Excess solder causes "bridging" between pads or leads

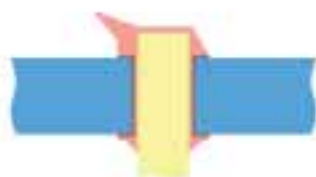

Solder "spikes" caused by low solder temperature- liable to cause short-circuiting

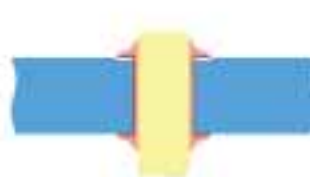

Lifted pads or tracks due to excessive heat

Press-fit technology: 100% reliability

Insertion

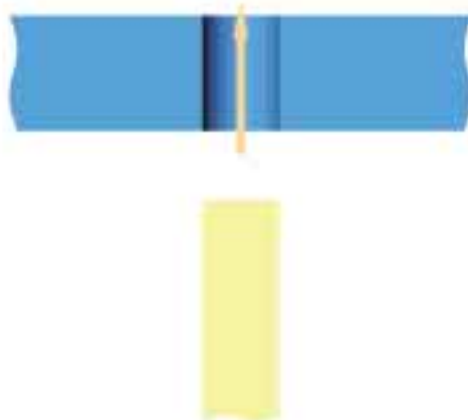

Connection

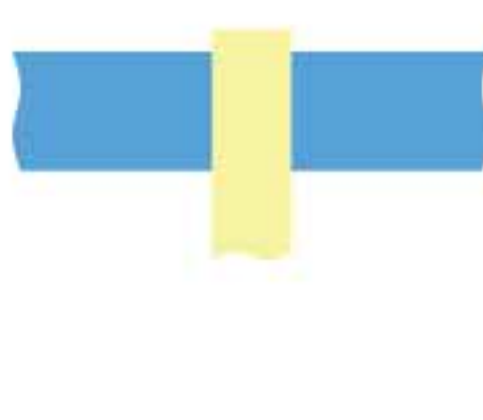

- ☞ there is a need for repairability,
- ☞ other components are press-fit components (such as multipin connectors),
- ☞ the connector is too large for surface-mount techniques (for example for DIN 1.6/5.6 or BNC series)
- ☞ Instead of hand soldering (safer, faster, cheaper),
- ☞ other components on the board may be damaged by high temperatures of soldering processes,
- ☞ the use of soldering fluxes is restricted due to stringent environmental regulations.

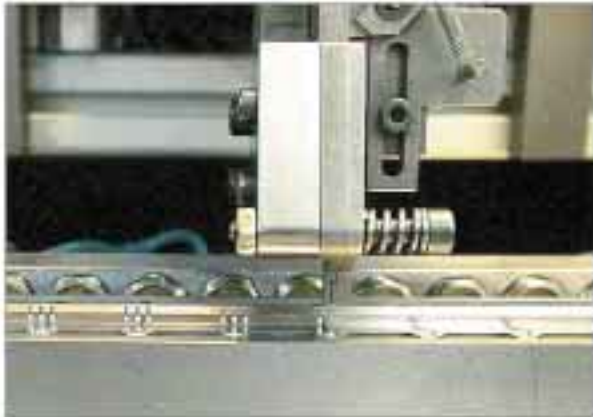

Connector manufacturing : press fit pins assembly line

◆ Plated holes

Implementation of holes for press-fit pins is easy: it uses a technology similar to the one used for soldering pins. To ensure a good retention, Coaxipress press-fit pins fit in normalized holes :

- 1 mm diameter plated holes (+0.09/-0.06).
- plating is the same as for traditional soldering technology: 25 μm copper min, 15 μm tin max.

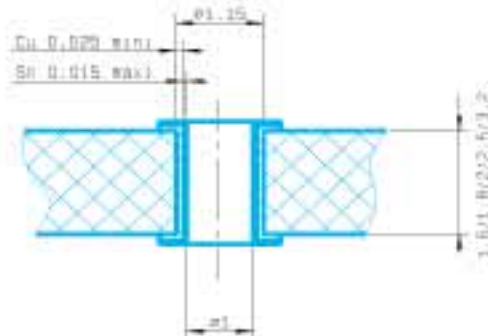

Plated holes can be used up to three times.

◆ Pins

The pins offered by Radiall for its Coaxipress connectors have the shape below, they are called "Bar-Bell" pins.

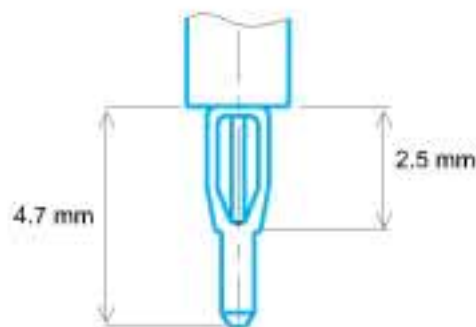

ADVANTAGES :

- ◆ They offer **very good mechanical and electrical performances** and comply with **IEC 352-5 requirements** (see table page 10).
- ◆ Pins are in phosphorous bronze, finished with tin-lead alloy (1.5 μm max) over nickel (1 to 2 μm). Thanks to the SnPb/SnPb contact between the compliant pin and the plated hole, the contact resistance is minimized.
- ◆ **Durability**: they meet IEC requirements (see table page 10) even after environmental tests such as:
 - rapid temperature change
 - moisture resistance
 - industrial atmosphere (SO₂ atmosphere)
 - electrical contact gas tightness (H₂S)
 - removal and replacement of components up to 3 times

Table

	IEC 352-5 requirements
Press-in force	250 N max
Push out force	20 N min
Initial contact resistance	1 m Ω max
Maximum change in contact resistance	1 m Ω max

◆ The shape of the pin is specifically designed to be as harmless as possible to the PCB:

- conical bottom part
- edges are rounded
- compliant part is elastic (resilient)

It is therefore possible to remove and replace components up to 3 times.

◆ "Bar-bell" pins can fit a wide range of PCB's. Compared to other pin shapes, these pins are particularly well-suited to thin PCBs (as thin as 1.6mm thick, no upper limitation).

For thinner PCBs, please contact us for more information.

◆ Compared to other compliant pins available on the market, their relatively short length (4.7 mm) minimizes antenna effect. Furthermore it is possible to further shorten them (down to 3.5 mm).

Sectional elevation of press fit pins pressed into the PCB



Cross section of press fit pins pressed into the PCB



Retention forces

Press-fit technology is a mechanically sound connection method.

Retention of the press-fit pins in the receptacle :

To ensure the best retention of the press-fit pins in the connector, Radiall designs most of its press-fit receptacles in brass with CuBe2 center contact.

Radiall guarantees a retention value per pin in the body of 40N.

For large receptacles, a specific design has been developed by Radiall (such as DIN 1.6/5.6, BNC, BR2... series), which ensures a retention value per pin in the body of 80N.

Retention of the connector in the PCB :

Radiall Coaxipress samples have successfully undergone pull off (F1), torsion (C1) and shear (F2) tests.

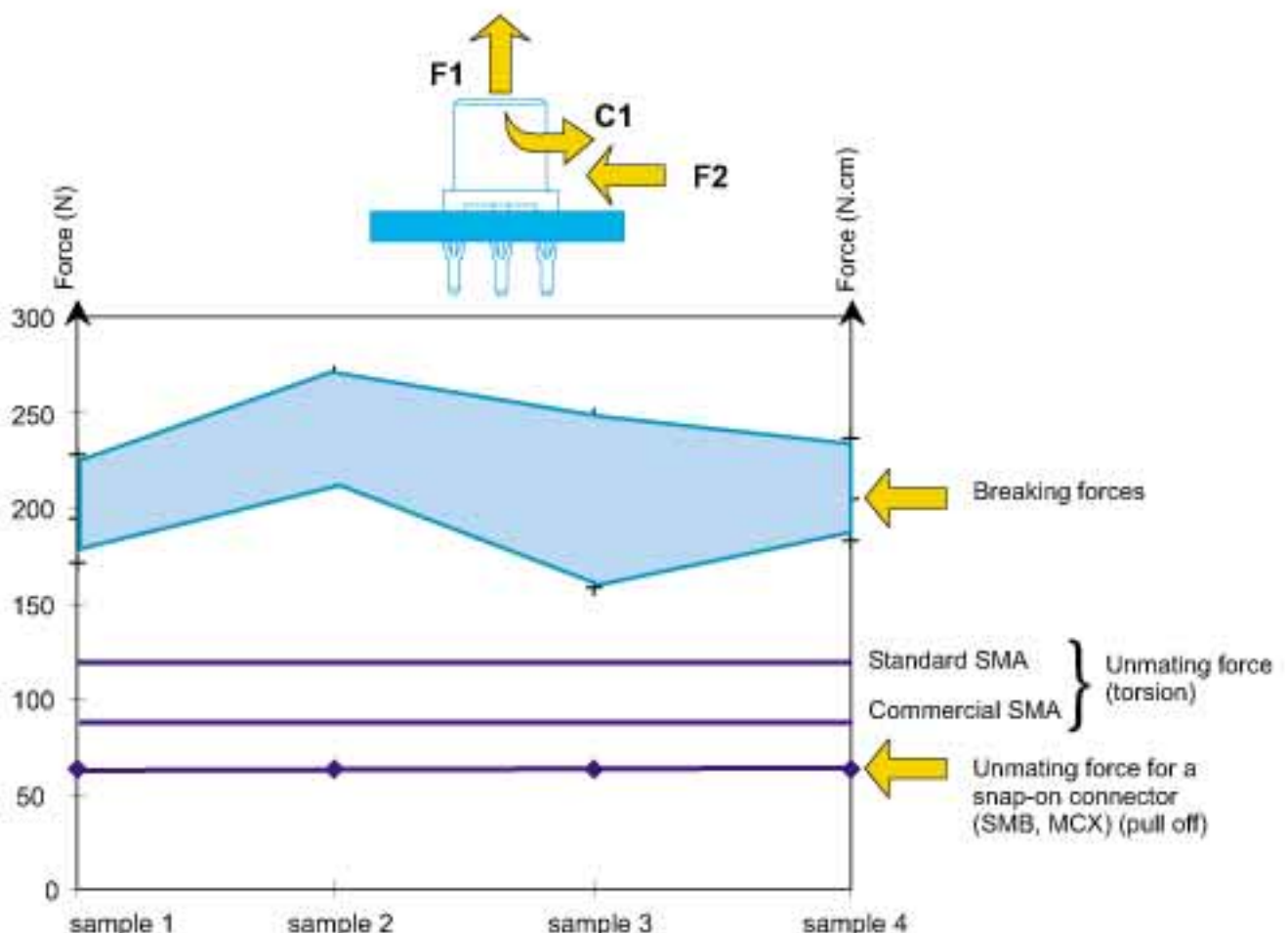

Breaking forces are about 3 times higher than unmatting forces, as shown above.

Therefore a receptacle cannot be accidentally pulled off when unmatting the couple of connectors.

Mounting of COAXIPRESS connectors on the PCB is very easy and reliable. Radiall offers specific tools which can be mounted on all standard automatic or hand operated press equipment:

- The PCB is placed on the lower tool and held in place by positioning pins.
- The upper tool transmits the required insertion force to the connector.

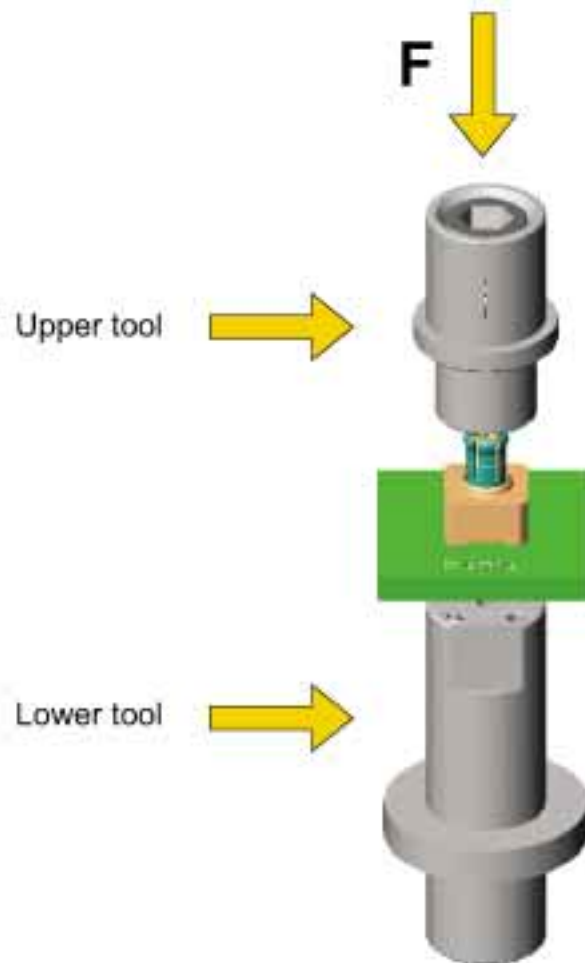

The upper tool is not required for right-angle connectors: the design of the connector makes it possible to transmit the insertion force directly.

Radiall can design custom tools, adapted to your specifications (for example: insertion of several connectors in a single operation)

It is **very easy** to replace a press-fit connector and there is **no risk** to damage the other components on the board (no soldering, therefore no need to apply heat).

The removal of a COAXIPRESS connector must be done from the back of the PCB, using special tools with ejectors. Using this method, there is no chance that a pin may accidentally remain in the plated holes.

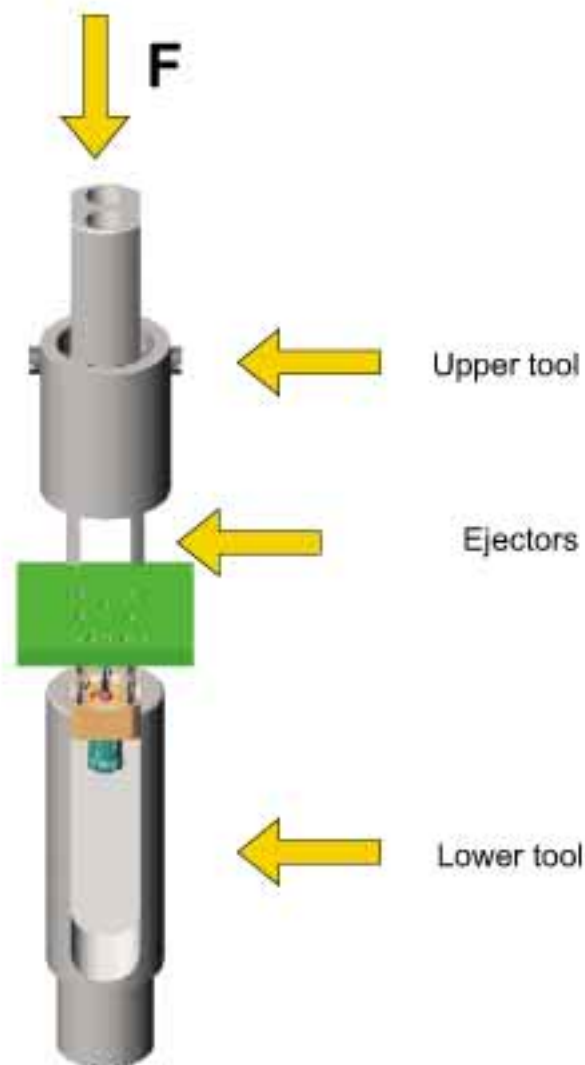

A COAXIPRESS connector itself can't be used twice, but **COAXIPRESS connectors can be removed and replaced up to 3 times.**

PRESS FIT TECHNOLOGY

For stringent environments (significant vibration, for example):

Radiall offers specific connectors, designed to further improve mechanical performances:

For example:



- ☞ a larger flange
- ☞ to replace 2 press-fit pins with 2 screws.

These custom connectors are available upon request.

Packaging

To bring the highest quality connections to our customer, Radiall Coaxpress connectors are not delivered in bulk packaging, but supplied in foam protected boxes.



Series	Imp. (Ω)	Part number	Designation	Quantity
MCX	50	R113 416 000	straight female PCB receptacle	100
		R113 416 020	straight female PCB receptacle	100
		R113 416 045 ●	straight female PCB receptacle	100
		R113 436 045 ●	straight male PCB receptacle	100
		R113 661 000	right angle female PCB receptacle	100
		R113 661 027	right angle female PCB receptacle	100
SMB	50	R114 416 000	straight male PCB receptacle	100
		R114 416 020	straight male PCB receptacle	100
		R114 661 020	right angle male PCB receptacle	100
1.0/2.3 screw-on	50	R118 574 000	straight female bulkhead PCB receptacle	40
1.0/2.3 slide-on	50	R120 415 500	straight female PCB receptacle	100
	75	R220 661 505 ●	right angle male PCB receptacle	40
DIN 41626	50	R120 416 507	straight male PCB receptacle	100
		R120 661 507 ●	right angle female PCB receptacle	100
Commercial SMA	50	R124 436 000	straight female PCB receptacle	100
		R124 674 023	straight female bulkhead PCB receptacle	100
SMA	50	R125 674 120 ●	right angle female PCB receptacle	100
SMZ BT43	75	R214 416 030 ●	straight male PCB receptacle (long version)	100
		R214 416 700	straight male PCB receptacle	100
Commercial BMA	50	R128 405 161 ●	straight male edge card receptacle	100
1.6/5.6 screw-on	50	R129 574 000	straight female bulkhead PCB receptacle	30
		R129 574 030	straight female bulkhead PCB receptacle	30
		R129 674 100 ●	right angle female bulkhead PCB receptacle	1
BNC	50	R141 416 000	straight female PCB receptacle	100
		R141 684 130	right angle female bulkhead PCB receptacle	10
TNC	50	R143 674 130 ●	right angle female bulkhead PCB receptacle	10
BR2		R605 416 000	straight female PCB receptacle	20
TQ	120	R608 416 207 ●	straight female PCB receptacle + 2 screws	

For more information, please ask for each series catalogs.

Radiall can supply, for large quantities, packaging in tubes for automated placement.

● Upon request